

TLC251, TLC251A, TLC251B, TLC251Y LinCMOS™ PROGRAMMABLE LOW-POWER OPERATIONAL AMPLIFIERS

SLOS001F – JULY 1983 – REVISED MARCH 2001

- **Wide Range of Supply Voltages**
1.4-V to 16-V
- **True Single-Supply Operation**
- **Common-Mode Input Voltage Range**
Includes the Negative Rail
- **Low Noise . . . 30 nV/√Hz Typ at 1-kHz**
(High Bias)
- **ESD Protection Exceeds 2000 V Per**
MIL-STD-883C, Method 3015.1

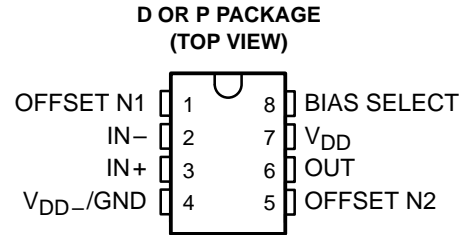

symbol

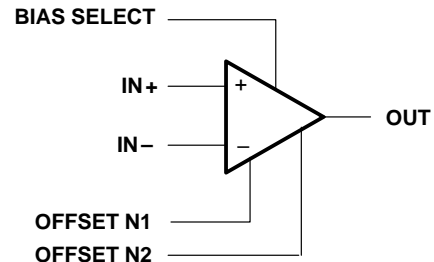

description

The TLC251C, TLC251AC, and TLC251BC are low-cost, low-power programmable operational amplifiers designed to operate with single or dual supplies. Unlike traditional metal-gate CMOS operational amplifiers, these devices utilize Texas Instruments silicon-gate LinCMOS™ process, giving them stable input offset voltages without sacrificing the advantages of metal-gate CMOS.

This series of parts is available in selected grades of input offset voltage and can be nulled with one external potentiometer. Because the input common-mode range extends to the negative rail and the power consumption is extremely low, this family is ideally suited for battery-powered or energy-conserving applications. A bias-select pin can be used to program one of three ac performance and power-dissipation levels to suit the application. The series features operation down to a 1.4-V supply and is stable at unity gain.

These devices have internal electrostatic-discharge (ESD) protection circuits that prevent catastrophic failures at voltages up to 2000 V as tested under MIL-STD-883C, Method 3015.1. However, care should be exercised in handling these devices as exposure to ESD may result in a degradation of the device parametric performance.

Because of the extremely high input impedance and low input bias and offset currents, applications for the TLC251C series include many areas that have previously been limited to BIFET and NFET product types. Any circuit using high-impedance elements and requiring small offset errors is a good candidate for cost-effective use of these devices. Many features associated with bipolar technology are available with LinCMOS™ operational amplifiers without the power penalties of traditional bipolar devices. Remote and inaccessible equipment applications are possible using the low-voltage and low-power capabilities of the TLC251C series.

In addition, by driving the bias-select input with a logic signal from a microprocessor, these operational amplifiers can have software-controlled performance and power consumption. The TLC251C series is well suited to solve the difficult problems associated with single battery and solar cell-powered applications.

The TLC251C series is characterized for operation from 0°C to 70°C.

AVAILABLE OPTIONS

T _A	V _{IOmax} AT 25°C	PACKAGED DEVICES		CHIP FORM (Y)
		SMALL OUTLINE (D)	PLASTIC DIP (P)	
0°C to 70°C	10 mV	TLC251CD	TLC251CP	TLC251Y
	5 mV	TLC251ACD	TLC251ACP	—
	2 mV	TLC251BCD	TLC251BCP	—

The D package is available taped and reeled. Add the suffix R to the device type (e.g., TLC251CDR). Chips are tested at 25°C.

LinCMOS is a trademark of Texas Instruments.

PRODUCTION DATA information is current as of publication date. Products conform to specifications per the terms of Texas Instruments standard warranty. Production processing does not necessarily include testing of all parameters.



POST OFFICE BOX 655303 • DALLAS, TEXAS 75265

Copyright © 2001, Texas Instruments Incorporated

TLC251, TLC251A, TLC251B, TLC251Y

LinCMOS™ PROGRAMMABLE LOW-POWER OPERATIONAL AMPLIFIERS

SLOS001F – JULY 1983 – REVISED MARCH 2001

schematic

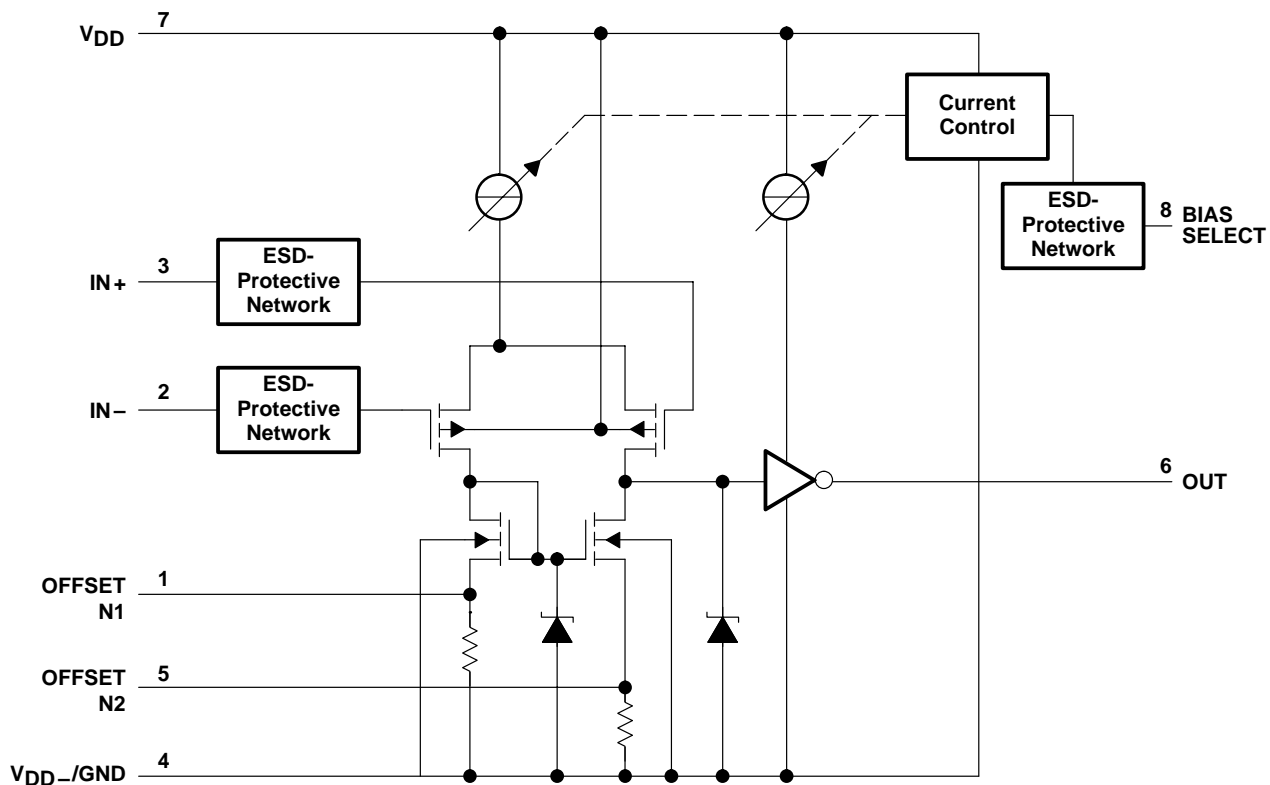

TLC251, TLC251A, TLC251B, TLC251Y
**LinCMOS™ PROGRAMMABLE
 LOW-POWER OPERATIONAL AMPLIFIERS**

SLOS001F – JULY 1983 – REVISED MARCH 2001

TLC251Y chip information

These chips, properly assembled, display characteristics similar to the TLC251C. Thermal compression or ultrasonic bonding may be used on the doped-aluminum bonding pads. Chips may be mounted with conductive epoxy or a gold-silicon preform.

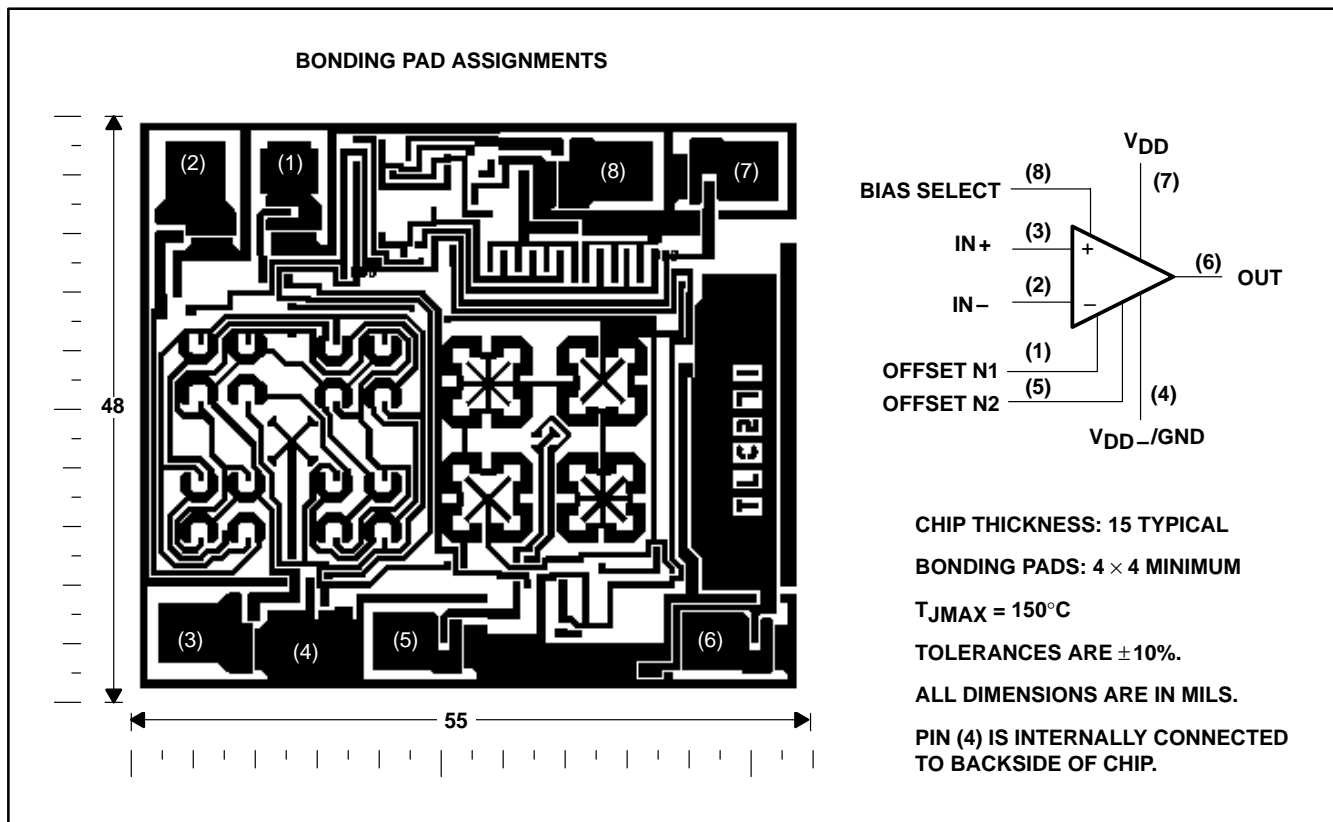

TLC251, TLC251A, TLC251B, TLC251Y
LinCMOS™ PROGRAMMABLE
LOW-POWER OPERATIONAL AMPLIFIERS

SLOS001F – JULY 1983 – REVISED MARCH 2001

absolute maximum ratings over operating free-air temperature range (unless otherwise noted)†

Supply voltage, V_{DD} (see Note 1)	18 V
Differential input voltage, V_{ID} (see Note 2)	± 18 V
Input voltage range, V_I (any input)	-0.3 V to 18 V
Duration of short circuit at (or below) 25°C free-air temperature (see Note 3)	unlimited
Continuous total dissipation	See Dissipation Rating Table
Operating free-air temperature range, T_A	0°C to 70°C
Storage temperature range	-65°C to 150°C
Lead temperature 1,6 mm (1/16 inch) from case for 10 seconds	260°C

† Stresses beyond those listed under “absolute maximum ratings” may cause permanent damage to the device. These are stress ratings only, and functional operation of the device at these or any other conditions beyond those indicated under “recommended operating conditions” is not implied. Exposure to absolute-maximum-rated conditions for extended periods may affect device reliability.

- NOTES: 1. All voltage values, except differential voltages, are with respect to V_{DD-}/GND .
 2. Differential voltages are at $IN+$ with respect to $IN-$.
 3. The output may be shorted to either supply. Temperature and/or supply voltages must be limited to ensure the maximum dissipation rating is not exceeded.

DISSIPATION RATING TABLE

PACKAGE	$T_A \leq 25^\circ\text{C}$ POWER RATING	DERATING FACTOR ABOVE $T_A = 25^\circ\text{C}$	$T_A = 70^\circ\text{C}$ POWER RATING
D	725 mW	5.8 mW/°C	464 mW
P	1000 mW	8.0 mW/°C	640 mW

recommended operating conditions

		MIN	MAX	UNIT
Supply voltage, V_{DD}		1.4	16	V
Common-mode input voltage, V_{IC}	$V_{DD} = 1.4$ V	0	0.2	V
	$V_{DD} = 5$ V	-0.2	4	
	$V_{DD} = 10$ V	-0.2	9	
	$V_{DD} = 16$ V	-0.2	14	
Operating free-air temperature, T_A		0	70	°C
Bias-select voltage		See Application Information		



TLC251, TLC251A, TLC251B, TLC251Y
LinCMOS™ PROGRAMMABLE
LOW-POWER OPERATIONAL AMPLIFIERS

SLOS001F – JULY 1983 – REVISED MARCH 2001

HIGH-BIAS MODE

electrical characteristics at specified free-air temperature

PARAMETER		TEST CONDITIONS	T _A †	TLC251C, TLC251AC, TLC251BC						UNIT
				V _{DD} = 5 V			V _{DD} = 10 V			
				MIN	TYP	MAX	MIN	TYP	MAX	
V _{IO}	Input offset voltage	TLC251C TLC251AC TLC251BC	V _O = 1.4 V, V _{IC} = 0 V, R _S = 50 Ω, R _L = 10 kΩ	25°C	1.1 10		1.1 10		mV	
				Full range	12		12			
				25°C	0.9 5		0.9 5			
				Full range	6.5		6.5			
				25°C	0.34 2		0.39 2			
				Full range	3		3			
α _{VIO}	Average temperature coefficient of input offset voltage		25°C to 70°C	1.8		2		μV/°C		
I _{IO}	Input offset current (see Note 4)	V _O = V _{DD} /2, V _{IC} = V _{DD} /2	25°C	0.1 60		0.1 60		pA		
			70°C	7 300		7 300				
I _{IB}	Input bias current (see Note 4)	V _O = V _{DD} /2, V _{IC} = V _{DD} /2	25°C	0.6 60		0.7 60		pA		
			70°C	40 600		50 600				
V _{ICR}	Common-mode input voltage range (see Note 5)		25°C	-0.2 to 4	-0.3 to 4.2	-0.2 to 9	-0.3 to 9.2	V		
			Full range	-0.2 to 3.5		-0.2 to 8.5		V		
V _{OH}	High-level output voltage	V _{ID} = 100 mV, R _L = 10 kΩ	25°C	3.2 3.8		8 8.5		V		
			0°C	3 3.8		7.8 8.5				
			70°C	3 3.8		7.8 8.4				
V _{OL}	Low-level output voltage	V _{ID} = -100 mV, I _{OL} = 0	25°C	0 50		0 50		mV		
			0°C	0 50		0 50				
			70°C	0 50		0 50				
A _{VD}	Large-signal differential voltage amplification	R _L = 10 kΩ, See Note 6	25°C	5 23		10 36		V/mV		
			0°C	4 27		7.5 42				
			70°C	4 20		7.5 32				
CMRR	Common-mode rejection ratio	V _{IC} = V _{ICRmin}	25°C	65 80		65 85		dB		
			0°C	60 84		60 88				
			70°C	60 85		60 88				
k _{SVR}	Supply-voltage rejection ratio (ΔV _{DD} /ΔV _{IO})	V _{DD} = 5 V to 10 V, V _O = 1.4 V	25°C	65 95		65 95		dB		
			0°C	60 94		60 94				
			70°C	60 96		60 96				
I _{I(SEL)}	Input current (BIAS SELECT)	V _{I(SEL)} = 0	25°C	-1.4		-1.9		μA		
I _{DD}	Supply current	V _O = V _{DD} /2, V _{IC} = V _{DD} /2, No load	25°C	675 1600		950 2000		μA		
			0°C	775 1800		1125 2200				
			70°C	575 1300		750 1700				

† Full range is 0°C to 70°C.

- NOTES:
4. The typical values of input bias current and input offset current below 5 pA were determined mathematically.
 5. This range also applies to each input individually.
 6. At V_{DD} = 5 V, V_O = 0.25 V to 2 V; at V_{DD} = 10 V, V_O = 1 V to 6 V.



TLC251, TLC251A, TLC251B, TLC251Y
LinCMOS™ PROGRAMMABLE
LOW-POWER OPERATIONAL AMPLIFIERS

SLOS001F – JULY 1983 – REVISED MARCH 2001

HIGH-BIAS MODE

operating characteristics, $V_{DD} = 5\text{ V}$

PARAMETER	TEST CONDITIONS	T_A	TLC251C, TLC251AC, TLC251BC			UNIT
			MIN	TYP	MAX	
SR Slew rate at unity gain	$R_L = 10\text{ k}\Omega$, $C_L = 20\text{ pF}$	$V_{I(PP)} = 1\text{ V}$	25°C	3.6		V/ μ s
			0°C	4		
			70°C	3		
		$V_{I(PP)} = 2.5\text{ V}$	25°C	2.9		
			0°C	3.1		
			70°C	2.5		
V_n Equivalent input noise voltage	$f = 1\text{ kHz}$, $R_S = 20\ \Omega$	25°C	25		nV/ $\sqrt{\text{Hz}}$	
B_{OM} Maximum output-swing bandwidth	$V_O = V_{OH}$, $C_L = 20\text{ pF}$, $R_L = 10\text{ k}\Omega$	25°C	320		kHz	
		0°C	340			
		70°C	260			
B_1 Unity-gain bandwidth	$V_I = 10\text{ mV}$, $C_L = 20\text{ pF}$	25°C	1.7		MHz	
		0°C	2			
		70°C	1.3			
ϕ_m Phase margin	$V_I = 10\text{ mV}$, $f = B_1$, $C_L = 20\text{ pF}$	25°C	46°			
		0°C	47°			
		70°C	44°			

operating characteristics, $V_{DD} = 10\text{ V}$

PARAMETER	TEST CONDITIONS	T_A	TLC251C, TLC251AC, TLC251BC			UNIT
			MIN	TYP	MAX	
SR Slew rate at unity gain	$R_L = 10\text{ k}\Omega$, $C_L = 20\text{ pF}$	$V_{I(PP)} = 1\text{ V}$	25°C	5.3		V/ μ s
			0°C	5.9		
			70°C	4.3		
		$V_{I(PP)} = 5.5\text{ V}$	25°C	4.6		
			0°C	5.1		
			70°C	3.8		
V_n Equivalent input noise voltage	$f = 1\text{ kHz}$, $R_S = 20\ \Omega$	25°C	25		nV/ $\sqrt{\text{Hz}}$	
B_{OM} Maximum output-swing bandwidth	$V_O = V_{OH}$, $C_L = 20\text{ pF}$, $R_L = 10\text{ k}\Omega$	25°C	200		kHz	
		0°C	220			
		70°C	140			
B_1 Unity-gain bandwidth	$V_I = 10\text{ mV}$, $C_L = 20\text{ pF}$	25°C	2.2		MHz	
		0°C	2.5			
		70°C	1.8			
ϕ_m Phase margin	$V_I = 10\text{ mV}$, $f = B_1$, $C_L = 20\text{ pF}$	25°C	49°			
		0°C	50°			
		70°C	46°			



TLC251, TLC251A, TLC251B, TLC251Y
LinCMOS™ PROGRAMMABLE
LOW-POWER OPERATIONAL AMPLIFIERS

SLOS001F – JULY 1983 – REVISED MARCH 2001

MEDIUM-BIAS MODE

electrical characteristics at specified free-air temperature

PARAMETER		TEST CONDITIONS	T _A †	TLC251C, TLC251AC, TLC251BC						UNIT
				V _{DD} = 5 V			V _{DD} = 10 V			
				MIN	TYP	MAX	MIN	TYP	MAX	
V _{IO}	Input offset voltage	TLC251C TLC251AC TLC251BC	V _O = 1.4 V, V _{IC} = 0 V, R _S = 50 Ω, R _L = 10 kΩ	25°C	1.1 10		1.1 10		mV	
				Full range	12		12			
				25°C	0.9 5		0.9 5			
				Full range	6.5		6.5			
				25°C	0.34 2		0.39 2			
				Full range	3		3			
α _{VIO}	Average temperature coefficient of input offset voltage		25°C to 70°C	1.7		2.1		μV/°C		
I _{IO}	Input offset current (see Note 4)	V _O = V _{DD} /2, V _{IC} = V _{DD} /2	25°C	0.1 60		0.1 60		pA		
			70°C	7 300		7 300				
I _{IB}	Input bias current (see Note 4)	V _O = V _{DD} /2, V _{IC} = V _{DD} /2	25°C	0.6 60		0.7 60		pA		
			70°C	40 600		50 600				
V _{ICR}	Common-mode input voltage range (see Note 5)		25°C	-0.2 to 4	-0.3 to 4.2	-0.2 to 9	-0.3 to 9.2	V		
			Full range	-0.2 to 3.5		-0.2 to 8.5		V		
V _{OH}	High-level output voltage	V _{ID} = 100 mV, R _L = 10 kΩ	25°C	3.2	3.9	8	8.7	V		
			0°C	3	3.9	7.8	8.7			
			70°C	3	4	7.8	8.7			
V _{OL}	Low-level output voltage	V _{ID} = -100 mV, I _{OL} = 0	25°C	0 50		0 50		mV		
			0°C	0 50		0 50				
			70°C	0 50		0 50				
A _{VD}	Large-signal differential voltage amplification	R _L = 10 kΩ, See Note 6	25°C	25	170	25	275	V/mV		
			0°C	15	200	15	320			
			70°C	15	140	15	230			
CMRR	Common-mode rejection ratio	V _{IC} = V _{ICRmin}	25°C	65	91	65	94	dB		
			0°C	60	91	60	94			
			70°C	60	92	60	94			
k _{SVR}	Supply-voltage rejection ratio (ΔV _{DD} /ΔV _{IO})	V _{DD} = 5 V to 10 V, V _O = 1.4 V	25°C	70	93	70	93	dB		
			0°C	60	92	60	92			
			70°C	60	94	60	94			
I _{I(SEL)}	Input current (BIAS SELECT)	V _{I(SEL)} = V _{DD} /2	25°C	-130		-160		nA		
I _{DD}	Supply current	V _O = V _{DD} /2, V _{IC} = V _{DD} /2, No load	25°C	105	280	143	300	μA		
			0°C	125	320	173	400			
			70°C	85	220	110	280			

† Full range is 0°C to 70°C.

- NOTES:
4. The typical values of input bias current and input offset current below 5 pA were determined mathematically.
 5. This range also applies to each input individually.
 6. At V_{DD} = 5 V, V_O = 0.25 V to 2 V; at V_{DD} = 10 V, V_O = 1 V to 6 V.



TLC251, TLC251A, TLC251B, TLC251Y
LinCMOS™ PROGRAMMABLE
LOW-POWER OPERATIONAL AMPLIFIERS

SLOS001F – JULY 1983 – REVISED MARCH 2001

MEDIUM-BIAS MODE

operating characteristics, $V_{DD} = 5\text{ V}$

PARAMETER	TEST CONDITIONS	T_A	TLC251C, TLC251AC, TLC251BC			UNIT
			MIN	TYP	MAX	
SR Slew rate at unity gain	$R_L = 100\text{ k}\Omega$, $C_L = 20\text{ pF}$	$V_{I(PP)} = 1\text{ V}$	25°C	0.43		V/ μ s
			0°C	0.46		
			70°C	0.36		
		$V_{I(PP)} = 2.5\text{ V}$	25°C	0.40		
			0°C	0.43		
			70°C	0.34		
V_n Equivalent input noise voltage	$f = 1\text{ kHz}$, $R_S = 20\ \Omega$	25°C	32		nV/ $\sqrt{\text{Hz}}$	
B_{OM} Maximum output-swing bandwidth	$V_O = V_{OH}$, $C_L = 20\text{ pF}$, $R_L = 100\text{ k}\Omega$	25°C	55		kHz	
		0°C	60			
		70°C	50			
B_1 Unity-gain bandwidth	$V_I = 10\text{ mV}$, $C_L = 20\text{ pF}$	25°C	525		kHz	
		0°C	600			
		70°C	400			
ϕ_m Phase margin	$V_I = 10\text{ mV}$, $f = B_1$, $C_L = 20\text{ pF}$	25°C	40°			
		0°C	41°			
		70°C	39°			

operating characteristics, $V_{DD} = 10\text{ V}$

PARAMETER	TEST CONDITIONS	T_A	TLC251C, TLC251AC, TLC251BC			UNIT
			MIN	TYP	MAX	
SR Slew rate at unity gain	$R_L = 100\text{ k}\Omega$, $C_L = 20\text{ pF}$	$V_{I(PP)} = 1\text{ V}$	25°C	0.62		V/ μ s
			0°C	0.67		
			70°C	0.51		
		$V_{I(PP)} = 5.5\text{ V}$	25°C	0.56		
			0°C	0.61		
			70°C	0.46		
V_n Equivalent input noise voltage	$f = 1\text{ kHz}$, $R_S = 20\ \Omega$	25°C	32		nV/ $\sqrt{\text{Hz}}$	
B_{OM} Maximum output-swing bandwidth	$V_O = V_{OH}$, $C_L = 20\text{ pF}$, $R_L = 100\text{ k}\Omega$	25°C	35		kHz	
		0°C	40			
		70°C	30			
B_1 Unity-gain bandwidth	$V_I = 10\text{ mV}$, $C_L = 20\text{ pF}$	25°C	635		kHz	
		0°C	710			
		70°C	510			
ϕ_m Phase margin	$V_I = 10\text{ mV}$, $f = B_1$, $C_L = 20\text{ pF}$	25°C	43°			
		0°C	44°			
		70°C	42°			



TLC251, TLC251A, TLC251B, TLC251Y
LinCMOS™ PROGRAMMABLE
LOW-POWER OPERATIONAL AMPLIFIERS

SLOS001F – JULY 1983 – REVISED MARCH 2001

LOW-BIAS MODE

electrical characteristics at specified free-air temperature

PARAMETER		TEST CONDITIONS	T _A †	TLC251C, TLC251AC, TLC251BC						UNIT
				V _{DD} = 5 V			V _{DD} = 10 V			
				MIN	TYP	MAX	MIN	TYP	MAX	
V _{IO}	Input offset voltage	TLC251C TLC251AC TLC251BC	V _O = 1.4 V, V _{IC} = 0 V, R _S = 50 Ω, R _L = 10 MΩ	25°C	1.1 10		1.1 10		mV	
				Full range	12		12			
				25°C	0.9 5		0.9 5			
				Full range	6.5		6.5			
				25°C	0.24 2		0.26 2			
				Full range	3		3			
α _{VIO}	Average temperature coefficient of input offset voltage		25°C to 70°C	1.1		1		μV/°C		
I _{IO}	Input offset current (see Note 4)	V _O = V _{DD} /2, V _{IC} = V _{DD} /2	25°C	0.1 60		0.1 60		pA		
			70°C	7 300		7 300				
I _{IB}	Input bias current (see Note 4)	V _O = V _{DD} /2, V _{IC} = V _{DD} /2	25°C	0.6 60		0.7 60		pA		
			70°C	40 600		50 600				
V _{ICR}	Common-mode input voltage range (see Note 5)		25°C	-0.2 to 4	-0.3 to 4.2	-0.2 to 9	-0.3 to 9.2	V		
			Full range	-0.2 to 3.5		-0.2 to 8.5		V		
V _{OH}	High-level output voltage	V _{ID} = 100 mV, R _L = 1 MΩ	25°C	3.2 4.1		8 8.9		V		
			0°C	3 4.1		7.8 8.9				
			70°C	3 4.2		7.8 8.9				
V _{OL}	Low-level output voltage	V _{ID} = -100 mV, I _{OL} = 0	25°C	0 50		0 50		mV		
			0°C	0 50		0 50				
			70°C	0 50		0 50				
A _{VD}	Large-signal differential voltage amplification	R _L = 1 MΩ, See Note 6	25°C	50 520		50 870		V/mV		
			0°C	50 700		50 1030				
			70°C	50 380		50 660				
CMRR	Common-mode rejection ratio	V _{IC} = V _{ICRmin}	25°C	65 94		65 97		dB		
			0°C	60 95		60 97				
			70°C	60 95		60 97				
k _{SVR}	Supply-voltage rejection ratio (ΔV _{DD} /ΔV _{IO})	V _{DD} = 5 V to 10 V, V _O = 1.4 V	25°C	70 97		70 97		dB		
			0°C	60 97		60 97				
			70°C	60 98		60 98				
I _{I(SEL)}	Input current (BIAS SELECT)	V _{I(SEL)} = V _{DD}	25°C	65		95		nA		
I _{DD}	Supply current	V _O = V _{DD} /2, V _{IC} = V _{DD} /2, No load	25°C	10 17		14 23		μA		
			0°C	12 21		18 33				
			70°C	8 14		11 20				

† Full range is 0°C to 70°C.

- NOTES:
4. The typical values of input bias current and input offset current below 5 pA were determined mathematically.
 5. This range also applies to each input individually.
 6. At V_{DD} = 5 V, V_O = 0.25 V to 2 V; at V_{DD} = 10 V, V_O = 1 V to 6 V.



TLC251, TLC251A, TLC251B, TLC251Y
LinCMOS™ PROGRAMMABLE
LOW-POWER OPERATIONAL AMPLIFIERS

SLOS001F – JULY 1983 – REVISED MARCH 2001

LOW-BIAS MODE

operating characteristics, $V_{DD} = 5\text{ V}$

PARAMETER	TEST CONDITIONS	T_A	TLC251C, TLC251AC, TLC251BC			UNIT
			MIN	TYP	MAX	
SR Slew rate at unity gain	$R_L = 1\text{ M}\Omega$, $C_L = 20\text{ pF}$	$V_{I(PP)} = 1\text{ V}$	25°C	0.03		V/ μ s
			0°C	0.04		
			70°C	0.03		
		$V_{I(PP)} = 2.5\text{ V}$	25°C	0.03		
			0°C	0.03		
			70°C	0.02		
V_n Equivalent input noise voltage	$f = 1\text{ kHz}$, $R_S = 20\ \Omega$	25°C	68		nV/ $\sqrt{\text{Hz}}$	
B_{OM} Maximum output-swing bandwidth	$V_O = V_{OH}$, $C_L = 20\text{ pF}$, $R_L = 1\text{ M}\Omega$	25°C	5		kHz	
		0°C	6			
		70°C	4.5			
B_1 Unity-gain bandwidth	$V_I = 10\text{ mV}$, $C_L = 20\text{ pF}$	25°C	85		kHz	
		0°C	100			
		70°C	65			
ϕ_m Phase margin	$V_I = 10\text{ mV}$, $f = B_1$, $C_L = 20\text{ pF}$	25°C	34°			
		0°C	36°			
		70°C	30°			

operating characteristics, $V_{DD} = 10\text{ V}$

PARAMETER	TEST CONDITIONS	T_A	TLC251C, TLC251AC, TLC251BC			UNIT
			MIN	TYP	MAX	
SR Slew rate at unity gain	$R_L = 1\text{ M}\Omega$, $C_L = 20\text{ pF}$	$V_{I(PP)} = 1\text{ V}$	25°C	0.05		V/ μ s
			0°C	0.05		
			70°C	0.04		
		$V_{I(PP)} = 5.5\text{ V}$	25°C	0.04		
			0°C	0.05		
			70°C	0.04		
V_n Equivalent input noise voltage	$f = 1\text{ kHz}$, $R_S = 20\ \Omega$	25°C	68		nV/ $\sqrt{\text{Hz}}$	
B_{OM} Maximum output-swing bandwidth	$V_O = V_{OH}$, $C_L = 20\text{ pF}$, $R_L = 1\text{ M}\Omega$	25°C	1		kHz	
		0°C	1.3			
		70°C	0.9			
B_1 Unity-gain bandwidth	$V_I = 10\text{ mV}$, $C_L = 20\text{ pF}$	25°C	110		kHz	
		0°C	125			
		70°C	90			
ϕ_m Phase margin	$V_I = 10\text{ mV}$, $f = B_1$, $C_L = 20\text{ pF}$	25°C	38°			
		0°C	40°			
		70°C	34°			



TLC251, TLC251A, TLC251B, TLC251Y
LinCMOS™ PROGRAMMABLE
LOW-POWER OPERATIONAL AMPLIFIERS

SLOS001F – JULY 1983 – REVISED MARCH 2001

electrical characteristics at specified free-air temperature, $V_{DD} = 1.4\text{ V}$

PARAMETER		TEST CONDITIONS†	T_A ‡	BIAS	TLC251C, TLC251AC, TLC251BC			UNIT
					MIN	TYP	MAX	
V_{IO}	Input offset voltage	$V_O = 0.2\text{ V}$, $R_S = 50\ \Omega$	25°C	Any				mV
					Full range			
			25°C	Any				
					Full range			
			25°C	Any				
					Full range			
α_{VIO}	Average temperature coefficient of input offset voltage		25°C to 70°C	Any	1			$\mu\text{V}/^\circ\text{C}$
I_{IO}	Input offset current	$V_O = 0.2\text{ V}$	25°C	Any	1 60			pA
			Full range		300			
I_{IB}	Input bias current	$V_O = 0.2\text{ V}$	25°C	Any	1 60			pA
			Full range		600			
V_{ICR}	Common-mode input voltage range		25°C	Any	0 to 0.2			V
V_{OM}	Peak output voltage swing§	$V_{ID} = 100\text{ mV}$	25°C	Any	450	700		mV
A_{VD}	Large-signal differential voltage amplification	$V_O = 100\text{ to }300\text{ mV}$, $R_S = 50\ \Omega$	25°C	Low	20			
				High	10			
$CMRR$	Common-mode rejection ratio	$R_S = 50\ \Omega$, $V_{IC} = V_{ICRmin}$	25°C	Any	60	77		dB
I_{DD}	Supply current	$V_O = 0.2\text{ V}$, No load	25°C	Low	5 17			μA
				High	150 190			

† All characteristics are measured under open-loop conditions with zero common-mode input voltage unless otherwise specified. Unless otherwise noted, an output load resistor is connected from the output to ground and has the following values: for low bias, $R_L = 1\text{ M}\Omega$, for medium bias, $R_L = 100\text{ k}\Omega$, and for high bias, $R_L = 10\text{ k}\Omega$.

‡ Full range is 0°C to 70°C.

§ The output swings to the potential of V_{DD-}/GND .

operating characteristics, $V_{DD} = 1.4\text{ V}$, $T_A = 25^\circ\text{C}$

PARAMETER		TEST CONDITIONS	BIAS	TLC251C, TLC251AC, TLC251BC			UNIT
				MIN	TYP	MAX	
B_1	Unity-gain bandwidth	$C_L = 100\text{ pF}$	Low	12			kHz
			High	12			
SR	Slew rate at unity gain	See Figure 1	Low	0.001			$\text{V}/\mu\text{s}$
			High	0.1			
	Overshoot factor	See Figure 1	Low	35%			
			High	30%			



TLC251, TLC251A, TLC251B, TLC251Y
LinCMOS™ PROGRAMMABLE
LOW-POWER OPERATIONAL AMPLIFIERS

SLOS001F – JULY 1983 – REVISED MARCH 2001

electrical characteristics, $V_{DD} = 5\text{ V}$, $T_A = 25^\circ\text{C}$

PARAMETER	TEST CONDITIONS	TLC251Y									UNIT
		HIGH-BIAS MODE			MEDIUM-BIAS MODE			LOW-BIAS MODE			
		MIN	TYP	MAX	MIN	TYP	MAX	MIN	TYP	MAX	
V_{IO} Input offset voltage	$V_O = 1.4\text{ V}$, $V_{IC} = 0\text{ V}$, $R_S = 50\ \Omega$, R_L^\dagger		1.1	10		1.1	10		1.1	10	mV
α_{VIO} Average temperature coefficient of input offset voltage			1.8		1.7		1.1				$\mu\text{V}/^\circ\text{C}$
I_{IO} Input offset current (see Note 4)	$V_O = V_{DD}/2$, $V_{IC} = V_{DD}/2$		0.1	60		0.1	60		0.1	60	pA
I_{IB} Input bias current (see Note 4)	$V_O = V_{DD}/2$, $V_{IC} = V_{DD}/2$		0.6	60		0.6	60		0.6	60	pA
V_{ICR} Common-mode input voltage range (see Note 5)		-0.2 to 4	-0.3 to 4.2		-0.2 to 4	-0.3 to 4.2		-0.2 to 4	-0.3 to 4.2		V
V_{OH} High-level output voltage	$V_{ID} = 100\text{ mV}$, R_L^\dagger	3.2	3.8		3.2	3.9		3.2	4.1		V
V_{OL} Low-level output voltage	$V_{ID} = -100\text{ mV}$, $I_{OL} = 0$		0	50		0	50		0	50	mV
A_{VD} Large-signal differential voltage amplification	$V_O = 0.25\text{ V}$, R_L^\dagger	5	23		25	170		50	480		V/mV
CMRR Common-mode rejection ratio	$V_{IC} = V_{ICRmin}$	65	80		65	91		65	94		dB
k_{SVR} Supply-voltage rejection ratio ($\Delta V_{DD}/\Delta V_{IO}$)	$V_{DD} = 5\text{ V to }10\text{ V}$, $V_O = 1.4\text{ V}$	65	95		70	93		70	97		dB
$I_{I(SEL)}$ Input current (BIAS SELECT)	$V_{I(SEL)} = V_{DD}/2$		-1.4		-0.13		0.065				μA
I_{DD} Supply current	$V_O = V_{DD}/2$, $V_{IC} = V_{DD}/2$, No load		675	1600		105	280		10	17	μA

† For high-bias mode, $R_L = 10\text{ k}\Omega$; for medium-bias mode, $R_L = 100\text{ k}\Omega$; and for low-bias mode, $R_L = 1\text{ M}\Omega$.

NOTES: 4. The typical values of input bias current and input offset current below 5 pA were determined mathematically.

5. This range also applies to each input individually.



operating characteristics, $V_{DD} = 5\text{ V}$, $T_A = 25^\circ\text{C}$

PARAMETER	TEST CONDITIONS	TLC251Y									UNIT			
		HIGH-BIAS MODE			MEDIUM-BIAS MODE			LOW-BIAS MODE						
		MIN	TYP	MAX	MIN	TYP	MAX	MIN	TYP	MAX				
SR	Slew rate at unity gain R_L^\dagger , $C_L = 20\text{ pF}$	$V_I(\text{PP}) = 1\text{ V}$			3.6			0.43			0.03			V/ μs
		$V_I(\text{PP}) = 2.5\text{ V}$			2.9			0.40			0.03			
V_n	Equivalent input noise voltage $f = 1\text{ kHz}$, $R_S = 20\ \Omega$				25			32			68			nV/ $\sqrt{\text{Hz}}$
B _{OM}	Maximum output swing bandwidth $V_O = V_{OH}$, $R_L = 10\text{ k}\Omega$	$C_L = 20\text{ pF}$,			320			55			4.5			kHz
B ₁	Unity-gain bandwidth $V_I = 10\text{ mV}$, $C_L = 20\text{ pF}$				1700			525			65			kHz
ϕ_m	Phase margin $f = B_1$, $C_L = 20\text{ pF}$	$V_I = 10\text{ mV}$,			46°			40°			34°			

† For high-bias mode, $R_L = 10\text{ k}\Omega$; for medium-bias mode, $R_L = 100\text{ k}\Omega$; and for low-bias mode, $R_L = 1\text{ M}\Omega$.

PARAMETER MEASUREMENT INFORMATION

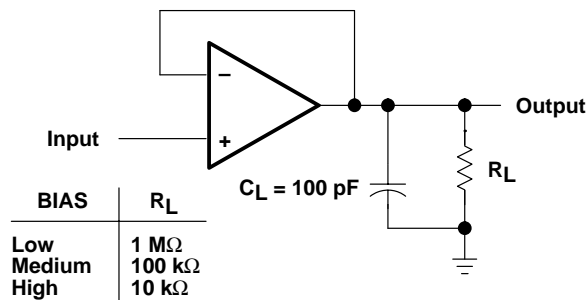

Figure 1. Unity-Gain Amplifier

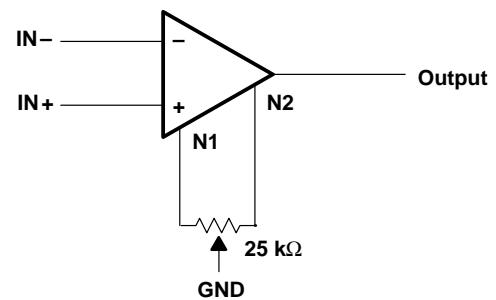

Figure 2. Input Offset Voltage Null Circuit

TYPICAL CHARACTERISTICS

Table of Graphs

			FIGURE
I_{DD}	Supply current	vs Bias-select voltage	3
		vs Supply voltage	4
		vs Free-air temperature	5
A_{VD}	Large-signal differential voltage amplification	Low bias vs Frequency	6
		Medium bias vs Frequency	7
		High bias vs Frequency	8
	Phase shift	Low bias vs Frequency	6
		Medium bias vs Frequency	7
		High bias vs Frequency	8

TYPICAL CHARACTERISTICS

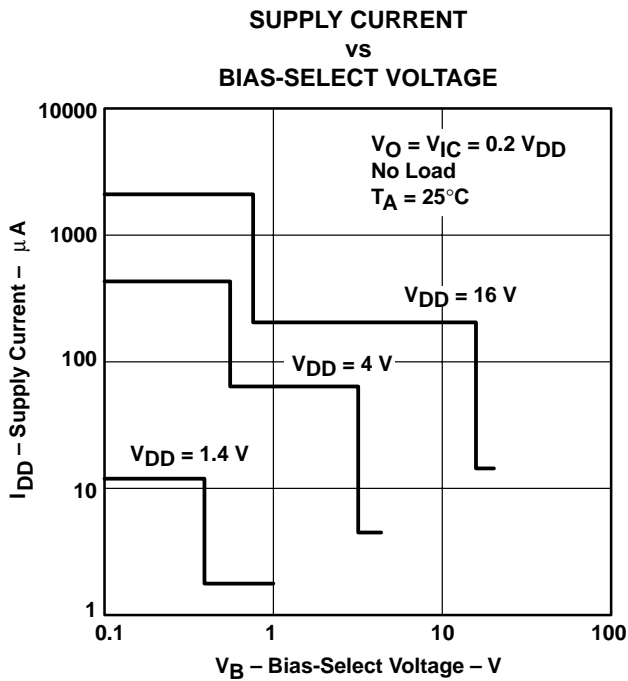

Figure 3

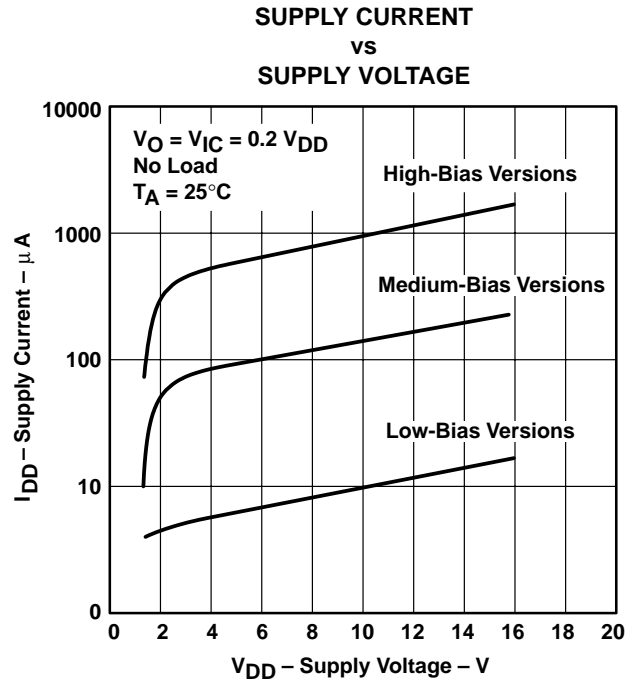

Figure 4

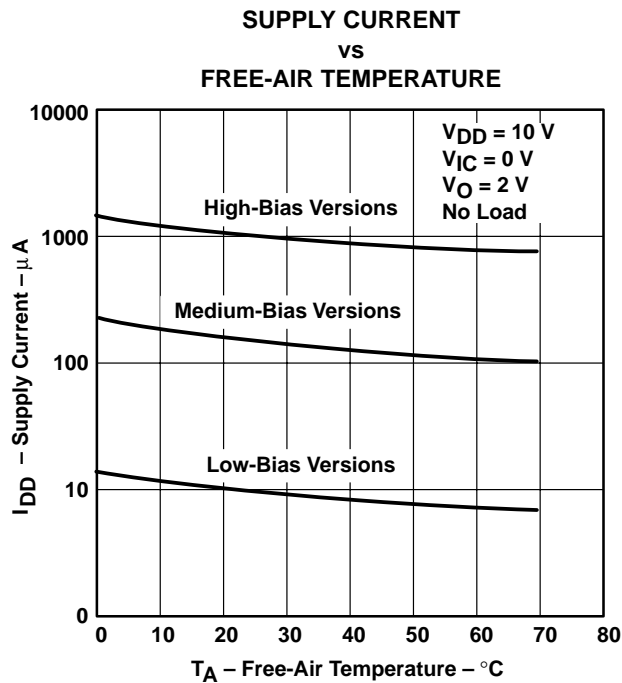

Figure 5

TYPICAL CHARACTERISTICS

**LOW-BIAS LARGE-SIGNAL
 DIFFERENTIAL VOLTAGE AMPLIFICATION
 AND PHASE SHIFT
 vs
 FREQUENCY**

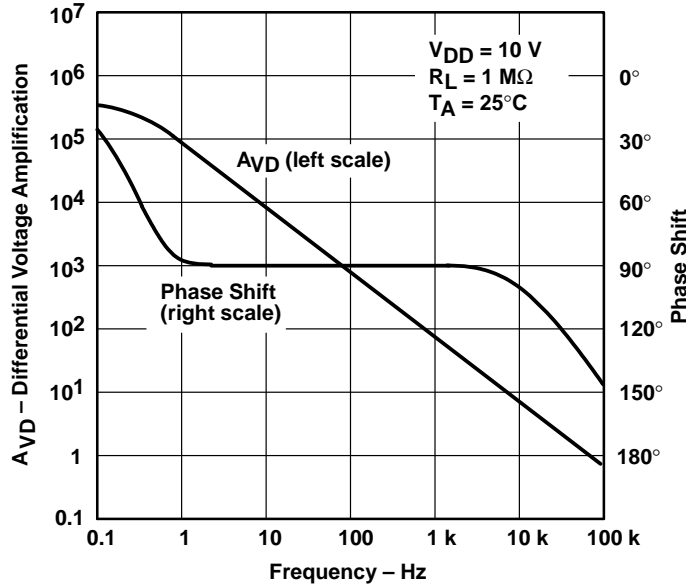

Figure 6

**MEDIUM-BIAS LARGE-SIGNAL
 DIFFERENTIAL VOLTAGE AMPLIFICATION
 AND PHASE SHIFT
 vs
 FREQUENCY**

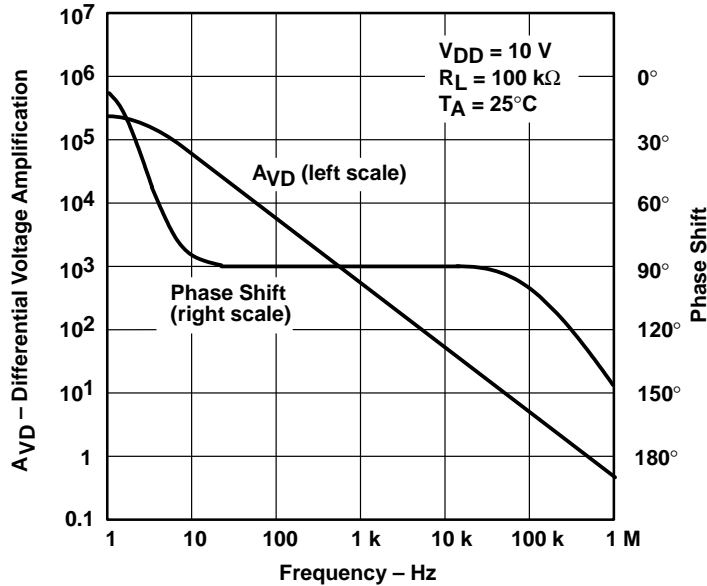

Figure 7

TYPICAL CHARACTERISTICS

HIGH-BIAS LARGE-SIGNAL
DIFFERENTIAL VOLTAGE AMPLIFICATION
AND PHASE SHIFT
vs
FREQUENCY

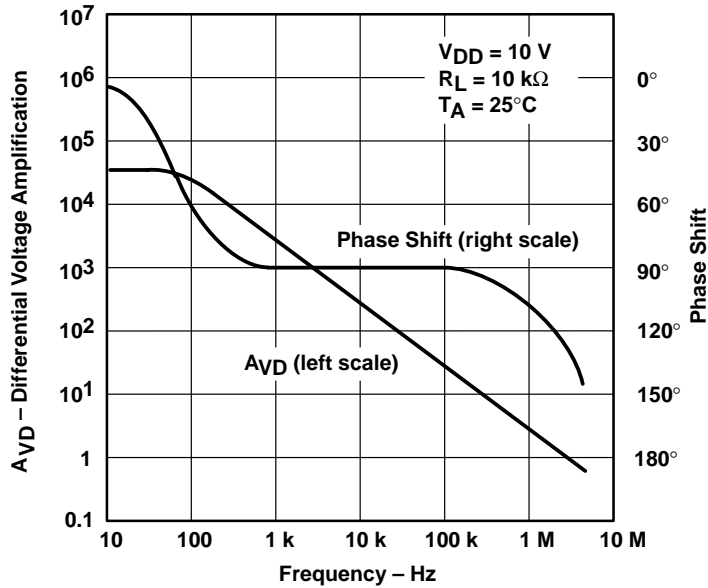

Figure 8

APPLICATION INFORMATION

latch-up avoidance

Junction-isolated CMOS circuits have an inherent parasitic PNP structure that can function as an SCR. Under certain conditions, this SCR may be triggered into a low-impedance state, resulting in excessive supply current. To avoid such conditions, no voltage greater than 0.3 V beyond the supply rails should be applied to any pin. In general, the operational amplifier supplies should be applied simultaneously with, or before, application of any input signals.

APPLICATION INFORMATION

using BIAS SELECT

The TLC251 has a terminal called BIAS SELECT that allows the selection of one of three I_{DD} conditions (10, 150, and 1000 μA typical). This allows the user to trade-off power and ac performance. As shown in the typical supply current (I_{DD}) versus supply voltage (V_{DD}) curves (Figure 4), the I_{DD} varies only slightly from 4 V to 16 V. Below 4 V, the I_{DD} varies more significantly. Note that the I_{DD} values in the medium- and low-bias modes at $V_{DD} = 1.4$ V are typically 2 μA , and in the high mode are typically 12 μA . The following table shows the recommended BIAS SELECT connections at $V_{DD} = 10$ V.

BIAS MODE	AC PERFORMANCE	BIAS SELECT CONNECTION†	TYPICAL $I_{DD}‡$
Low	Low	V_{DD}	10 μA
Medium	Medium	0.8 V to 9.2 V	150 μA
High	High	Ground pin	1000 μA

† Bias selection may also be controlled by external circuitry to conserve power, etc. For information regarding BIAS SELECT, see Figure 3 in the typical characteristics curves.

‡ For I_{DD} characteristics at voltages other than 10 V, see Figure 4 in the typical characteristics curves.

output stage considerations

The amplifier's output stage consists of a source-follower-connected pullup transistor and an open-drain pulldown transistor. The high-level output voltage (V_{OH}) is virtually independent of the I_{DD} selection and increases with higher values of V_{DD} and reduced output loading. The low-level output voltage (V_{OL}) decreases with reduced output current and higher input common-mode voltage. With no load, V_{OL} is essentially equal to the potential of V_{DD-}/GND .

input offset nulling

The TLC251C series offers external offset null control. Nulling may be achieved by adjusting a 25-k Ω potentiometer connected between the offset null terminals with the wiper connected to the device V_{DD-}/GND pin as shown in Figure 2. The amount of nulling range varies with the bias selection. At an I_{DD} setting of 1000 μA (high bias), the nulling range allows the maximum offset specified to be trimmed to zero. In low or medium bias or when the amplifier is used below 4 V, total nulling may not be possible for all units.

supply configurations

Even though the TLC251C series is characterized for single-supply operation, it can be used effectively in a split-supply configuration when the input common-mode voltage (V_{ICR}), output swing (V_{OL} and V_{OH}), and supply voltage limits are not exceeded.

circuit layout precautions

The user is cautioned that whenever extremely high circuit impedances are used, care must be exercised in layout, construction, board cleanliness, and supply filtering to avoid hum and noise pickup, as well as excessive dc leakages.

PACKAGING INFORMATION

Orderable Device	Status ⁽¹⁾	Package Type	Package Drawing	Pins	Package Qty	Eco Plan ⁽²⁾	Lead/Ball Finish	MSL Peak Temp ⁽³⁾
TLC251ACD	ACTIVE	SOIC	D	8	75	Green (RoHS & no Sb/Br)	CU NIPDAU	Level-1-260C-UNLIM
TLC251ACDG4	ACTIVE	SOIC	D	8	75	Green (RoHS & no Sb/Br)	CU NIPDAU	Level-1-260C-UNLIM
TLC251ACDR	ACTIVE	SOIC	D	8	2500	Green (RoHS & no Sb/Br)	CU NIPDAU	Level-1-260C-UNLIM
TLC251ACDRG4	ACTIVE	SOIC	D	8	2500	Green (RoHS & no Sb/Br)	CU NIPDAU	Level-1-260C-UNLIM
TLC251ACP	ACTIVE	PDIP	P	8	50	Pb-Free (RoHS)	CU NIPDAU	N / A for Pkg Type
TLC251ACPE4	ACTIVE	PDIP	P	8	50	Pb-Free (RoHS)	CU NIPDAU	N / A for Pkg Type
TLC251BCP	ACTIVE	PDIP	P	8	50	Pb-Free (RoHS)	CU NIPDAU	N / A for Pkg Type
TLC251BCPE4	ACTIVE	PDIP	P	8	50	Pb-Free (RoHS)	CU NIPDAU	N / A for Pkg Type
TLC251CD	ACTIVE	SOIC	D	8	75	Green (RoHS & no Sb/Br)	CU NIPDAU	Level-1-260C-UNLIM
TLC251CDG4	ACTIVE	SOIC	D	8	75	Green (RoHS & no Sb/Br)	CU NIPDAU	Level-1-260C-UNLIM
TLC251CDR	ACTIVE	SOIC	D	8	2500	Green (RoHS & no Sb/Br)	CU NIPDAU	Level-1-260C-UNLIM
TLC251CDRG4	ACTIVE	SOIC	D	8	2500	Green (RoHS & no Sb/Br)	CU NIPDAU	Level-1-260C-UNLIM
TLC251CP	ACTIVE	PDIP	P	8	50	Pb-Free (RoHS)	CU NIPDAU	N / A for Pkg Type
TLC251CPE4	ACTIVE	PDIP	P	8	50	Pb-Free (RoHS)	CU NIPDAU	N / A for Pkg Type
TLC251CPSR	ACTIVE	SO	PS	8	2000	Green (RoHS & no Sb/Br)	CU NIPDAU	Level-1-260C-UNLIM
TLC251CPSRG4	ACTIVE	SO	PS	8	2000	Green (RoHS & no Sb/Br)	CU NIPDAU	Level-1-260C-UNLIM

⁽¹⁾ The marketing status values are defined as follows:

ACTIVE: Product device recommended for new designs.

LIFEBUY: TI has announced that the device will be discontinued, and a lifetime-buy period is in effect.

NRND: Not recommended for new designs. Device is in production to support existing customers, but TI does not recommend using this part in a new design.

PREVIEW: Device has been announced but is not in production. Samples may or may not be available.

OBSOLETE: TI has discontinued the production of the device.

⁽²⁾ Eco Plan - The planned eco-friendly classification: Pb-Free (RoHS), Pb-Free (RoHS Exempt), or Green (RoHS & no Sb/Br) - please check <http://www.ti.com/productcontent> for the latest availability information and additional product content details.

TBD: The Pb-Free/Green conversion plan has not been defined.

Pb-Free (RoHS): TI's terms "Lead-Free" or "Pb-Free" mean semiconductor products that are compatible with the current RoHS requirements for all 6 substances, including the requirement that lead not exceed 0.1% by weight in homogeneous materials. Where designed to be soldered at high temperatures, TI Pb-Free products are suitable for use in specified lead-free processes.

Pb-Free (RoHS Exempt): This component has a RoHS exemption for either 1) lead-based flip-chip solder bumps used between the die and package, or 2) lead-based die adhesive used between the die and leadframe. The component is otherwise considered Pb-Free (RoHS compatible) as defined above.

Green (RoHS & no Sb/Br): TI defines "Green" to mean Pb-Free (RoHS compatible), and free of Bromine (Br) and Antimony (Sb) based flame retardants (Br or Sb do not exceed 0.1% by weight in homogeneous material)

⁽³⁾ MSL, Peak Temp. -- The Moisture Sensitivity Level rating according to the JEDEC industry standard classifications, and peak solder temperature.

Important Information and Disclaimer:The information provided on this page represents TI's knowledge and belief as of the date that it is provided. TI bases its knowledge and belief on information provided by third parties, and makes no representation or warranty as to the accuracy of such information. Efforts are underway to better integrate information from third parties. TI has taken and continues to take reasonable steps to provide representative and accurate information but may not have conducted destructive testing or chemical analysis on incoming materials and chemicals. TI and TI suppliers consider certain information to be proprietary, and thus CAS numbers and other limited information may not be available for release.

In no event shall TI's liability arising out of such information exceed the total purchase price of the TI part(s) at issue in this document sold by TI to Customer on an annual basis.

TAPE AND REEL INFORMATION



QUADRANT ASSIGNMENTS FOR PIN 1 ORIENTATION IN TAPE



*All dimensions are nominal

Device	Package Type	Package Drawing	Pins	SPQ	Reel Diameter (mm)	Reel Width W1 (mm)	A0 (mm)	B0 (mm)	K0 (mm)	P1 (mm)	W (mm)	Pin1 Quadrant
TLC251ACDR	SOIC	D	8	2500	330.0	12.4	6.4	5.2	2.1	8.0	12.0	Q1
TLC251CDR	SOIC	D	8	2500	330.0	12.4	6.4	5.2	2.1	8.0	12.0	Q1
TLC251CPSR	SO	PS	8	2000	330.0	16.4	8.2	6.6	2.5	12.0	16.0	Q1

TAPE AND REEL BOX DIMENSIONS



*All dimensions are nominal

Device	Package Type	Package Drawing	Pins	SPQ	Length (mm)	Width (mm)	Height (mm)
TLC251ACDR	SOIC	D	8	2500	346.0	346.0	29.0
TLC251CDR	SOIC	D	8	2500	346.0	346.0	29.0
TLC251CPSR	SO	PS	8	2000	346.0	346.0	33.0

IMPORTANT NOTICE

Texas Instruments Incorporated and its subsidiaries (TI) reserve the right to make corrections, modifications, enhancements, improvements, and other changes to its products and services at any time and to discontinue any product or service without notice. Customers should obtain the latest relevant information before placing orders and should verify that such information is current and complete. All products are sold subject to TI's terms and conditions of sale supplied at the time of order acknowledgment.

TI warrants performance of its hardware products to the specifications applicable at the time of sale in accordance with TI's standard warranty. Testing and other quality control techniques are used to the extent TI deems necessary to support this warranty. Except where mandated by government requirements, testing of all parameters of each product is not necessarily performed.

TI assumes no liability for applications assistance or customer product design. Customers are responsible for their products and applications using TI components. To minimize the risks associated with customer products and applications, customers should provide adequate design and operating safeguards.

TI does not warrant or represent that any license, either express or implied, is granted under any TI patent right, copyright, mask work right, or other TI intellectual property right relating to any combination, machine, or process in which TI products or services are used. Information published by TI regarding third-party products or services does not constitute a license from TI to use such products or services or a warranty or endorsement thereof. Use of such information may require a license from a third party under the patents or other intellectual property of the third party, or a license from TI under the patents or other intellectual property of TI.

Reproduction of TI information in TI data books or data sheets is permissible only if reproduction is without alteration and is accompanied by all associated warranties, conditions, limitations, and notices. Reproduction of this information with alteration is an unfair and deceptive business practice. TI is not responsible or liable for such altered documentation. Information of third parties may be subject to additional restrictions.

Resale of TI products or services with statements different from or beyond the parameters stated by TI for that product or service voids all express and any implied warranties for the associated TI product or service and is an unfair and deceptive business practice. TI is not responsible or liable for any such statements.

TI products are not authorized for use in safety-critical applications (such as life support) where a failure of the TI product would reasonably be expected to cause severe personal injury or death, unless officers of the parties have executed an agreement specifically governing such use. Buyers represent that they have all necessary expertise in the safety and regulatory ramifications of their applications, and acknowledge and agree that they are solely responsible for all legal, regulatory and safety-related requirements concerning their products and any use of TI products in such safety-critical applications, notwithstanding any applications-related information or support that may be provided by TI. Further, Buyers must fully indemnify TI and its representatives against any damages arising out of the use of TI products in such safety-critical applications.

TI products are neither designed nor intended for use in military/aerospace applications or environments unless the TI products are specifically designated by TI as military-grade or "enhanced plastic." Only products designated by TI as military-grade meet military specifications. Buyers acknowledge and agree that any such use of TI products which TI has not designated as military-grade is solely at the Buyer's risk, and that they are solely responsible for compliance with all legal and regulatory requirements in connection with such use.

TI products are neither designed nor intended for use in automotive applications or environments unless the specific TI products are designated by TI as compliant with ISO/TS 16949 requirements. Buyers acknowledge and agree that, if they use any non-designated products in automotive applications, TI will not be responsible for any failure to meet such requirements.

Following are URLs where you can obtain information on other Texas Instruments products and application solutions:

Products

Amplifiers	amplifier.ti.com
Data Converters	dataconverter.ti.com
DSP	dsp.ti.com
Clocks and Timers	www.ti.com/clocks
Interface	interface.ti.com
Logic	logic.ti.com
Power Mgmt	power.ti.com
Microcontrollers	microcontroller.ti.com
RFID	www.ti-rfid.com
RF/IF and ZigBee® Solutions	www.ti.com/lprf

Applications

Audio	www.ti.com/audio
Automotive	www.ti.com/automotive
Broadband	www.ti.com/broadband
Digital Control	www.ti.com/digitalcontrol
Medical	www.ti.com/medical
Military	www.ti.com/military
Optical Networking	www.ti.com/opticalnetwork
Security	www.ti.com/security
Telephony	www.ti.com/telephony
Video & Imaging	www.ti.com/video
Wireless	www.ti.com/wireless

Mailing Address: Texas Instruments, Post Office Box 655303, Dallas, Texas 75265
Copyright © 2008, Texas Instruments Incorporated